

Ringraumdichtungen geteilt

RRD-2-G/S

In geteilter, klappbarer Ausführung mit Schnellverschluss

Werkstoffe:

Scheiben:

Edelstahl Wst.-Nr. 1.4541 / 1.4571
s=5mm

Schrauben und Muttern:

V4A / V2A

Dichtung:

EPDM / s=20mm / Härte=50Shore
Bei druckwasserdichter Ausführung:
EPDM-Dichtungen s=27mm

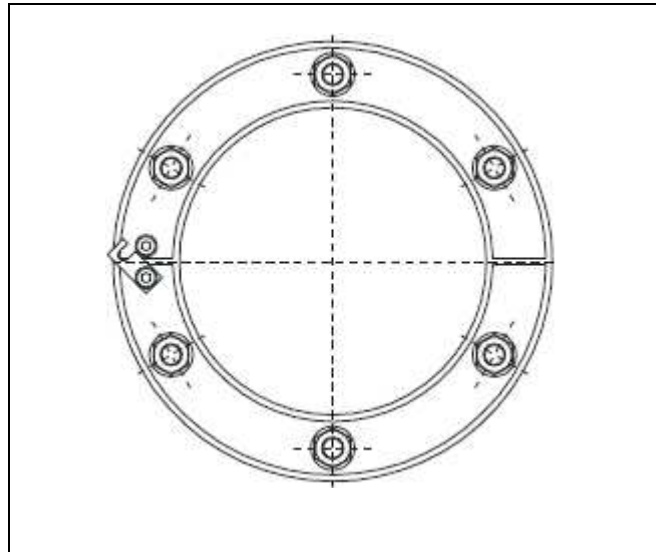

Abmessungen:

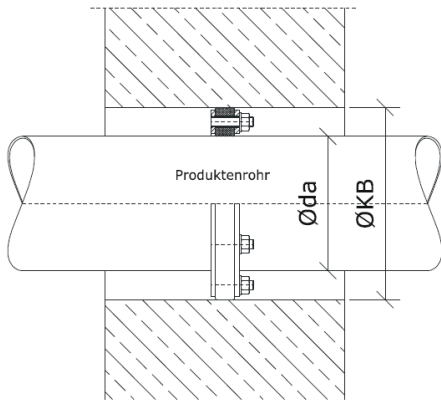
	Produktrohr	Kernbohrung
	da (mm)	KB (mm)
	60,3	125
	76,1	125
	88,9	150
	114,3	200
	139,7	200
	168,3	250
	219,1	300
	273,0	350/400
	323,9	450
	355,6	450/500
	406,4	500
	508,0	600

